



SNOWDRAGON INDUSTRIAL CO.,LTD

Customer Service :+86-755-83918797 +86-755-28269297

Fax: +86-755-83062997

Websites: www.snowdragonledhk.com www.snowdragonledproduct.com

LED Product Specification

Company Name :	
Product Number:	SD346BDR-OK-SL-C
Document Number :	
Product Description:	3mm Oval LED

CUSTOMER APPROVED BY			
Department			
Checked			
Signature			
Final confirmation of results			



Applications :

- Indoor and outdoor full color display
- Billboards
- Decorative Lighting
- Indicator

Features:

- 3mm Oval LED
- Lens Color: colored mist
- LED Color: Blue
- Half-power angle: 100 °
- Chip Material: GaN

Package Dimensions

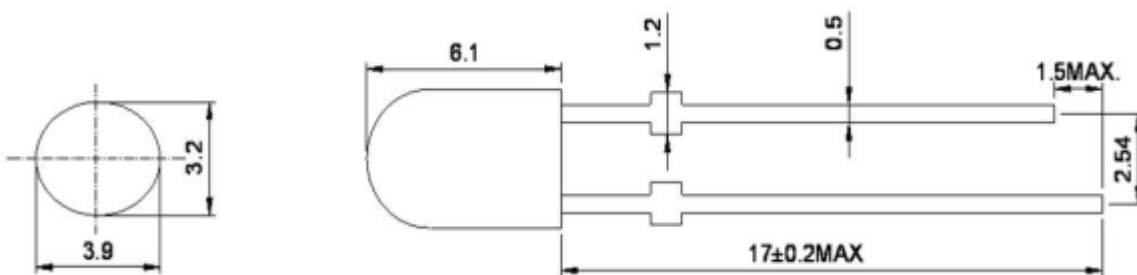

Note:

1. All dimensions are in mm
2. If no special instructions tolerance range $\pm 0.25\text{mm}$
3. Described in the technical data sheet are subject to change without notice.
4. The semiconductor device is static sensitive components, wear protective equipment pick up static electricity, all the machines, please do ground handling equipment.

Electrical / Optical Characteristics at TA=25°C

Symbol	Parameter	Device	Min.	Typ.	Max.	Units	Test Conditions
VF [1]	Forward Voltage	Blue	-	3	-	V	IF=10mA
IR	Reverse Current		-		10	uA	VR = 5V
Iv	Luminous intensity		220	-	286	mcd	IF=10mA
λ_d	Peak wavelength		468	-	472	nm	IF=10mA
2θ1/2H-H	Viewing Angle		-	100	-	deg	IF=10mA
2θ1/2V-V	Viewing Angle		-	44	-	deg	IF=10mA

Absolute Maximum Ratings at TA=25°C

Parameter	Symbol	Maximum size	Units
Power dissipation	PD	110	mW
Reverse Current	IF	30	mA
Peak Forward Current	IFP	100	mA
Reverse Voltage	VR	5	V
Operating Temperature		-40°C To +85°C	
Storage Temperature		-40°C To +85°C	

Pulse Width. \leq 0.1msec ; Duty Cycle \leq 1/10

Typical light - electric curve:

Forward Current vs. Dominant wavelength

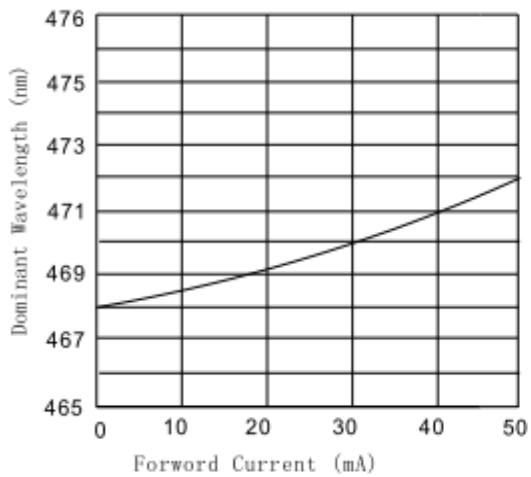

Relative Intensity vs. Ambient Temperature

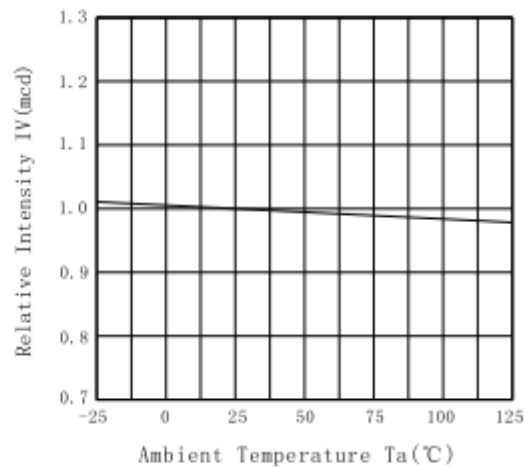

Forward Current vs. Forward Voltage

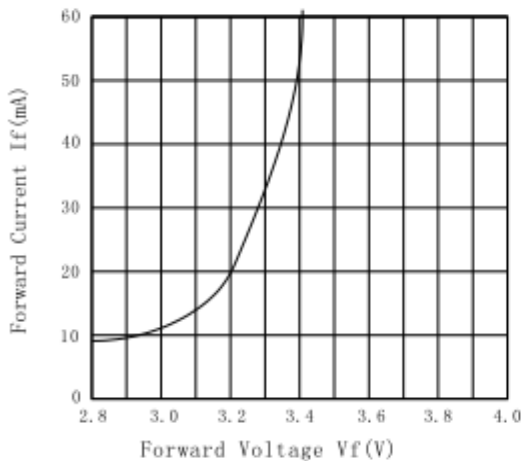

Forward Voltage vs. Ambient Temperature

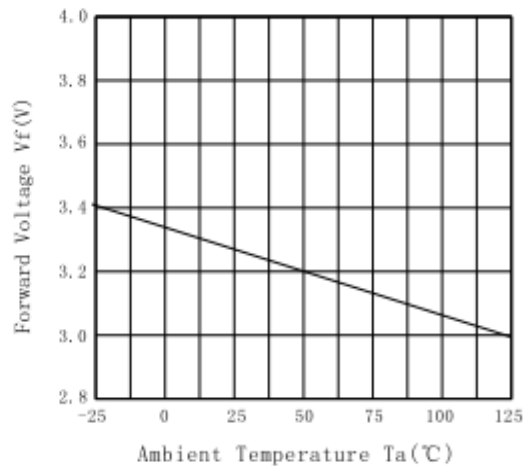

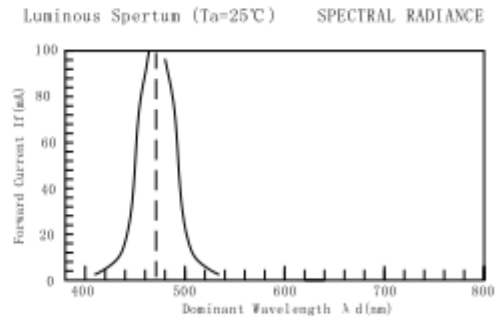
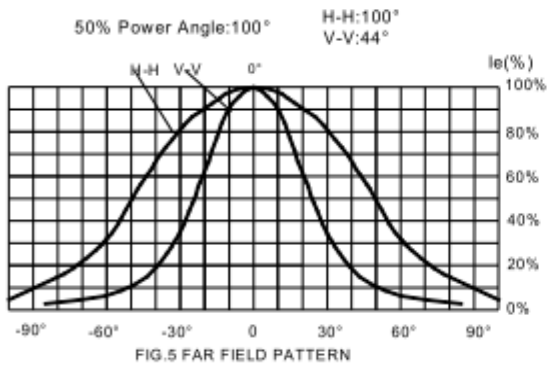

Drying agent

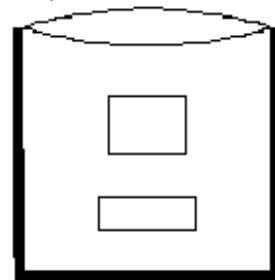

Anti-static Aluminum Bag
 100PCS/Bag

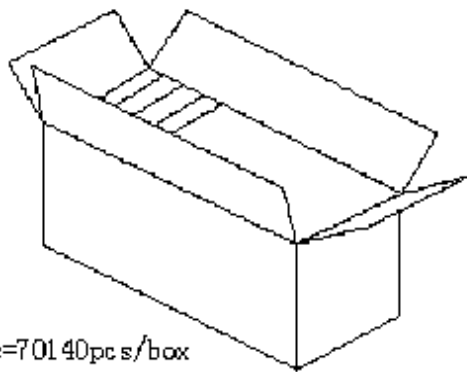

BOX(70包)
 70×1002pcs=70140pcs/box