



# SNOWDRAGON INDUSTRIAL CO.,LTD

Customer Service :+86-755-83918797 +86-755-28269297

Fax: +86-755-83062997

Websites: [www.snowdragonledhk.com](http://www.snowdragonledhk.com) [www.snowdragonledproduct.com](http://www.snowdragonledproduct.com)

## LED Product Specification

Company Name :	
Product Number:	SD346GDR-OK-SL-C
Document Number :	
Product Description:	3mm Oval LED

CUSTOMER APPROVED BY			
Department			
Checked			
Signature			
Final confirmation of results			

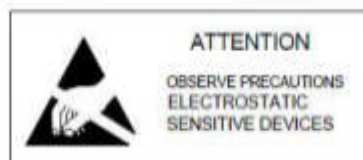

Applications :

- Indoor and outdoor full color display
- Billboards
- Decorative Lighting
- Indicator

Features:

- 3mm Oval LED
- Lens Color: colored mist
- LED Color: Green
- Half-power angle: 100 °
- Chip Material: GaN

Package Dimensions

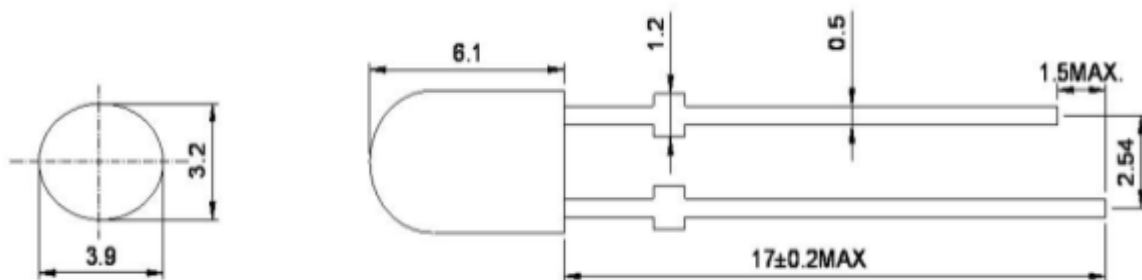

Note:

1. All dimensions are in mm
2. If no special instructions tolerance range  $\pm 0.25$ mm
3. Described in the technical data sheet are subject to change without notice.
4. The semiconductor device is static sensitive components, wear protective equipment pick up static electricity, all the machines, please do ground handling equipment.

Electrical / Optical Characteristics at TA=25°C

Symbol	Parameter	Device	Min.	Typ.	Max.	Units	Test Conditions
VF [1]	Forward Voltage	Green	-	3.2	-	V	IF=20mA
IR	Reverse Current		-		10	uA	VR = 5V
Iv	Luminous intensity		1820	-	2420	mcd	IF=20mA
$\lambda_d$	Peak wavelength		522	-	526	nm	IF=20mA
2 $\theta$ 1/2H-H	Viewing Angle		-	100	-	deg	IF=20mA
2 $\theta$ 1/2V-V	Viewing Angle		-	44	-	deg	IF=20mA

Absolute Maximum Ratings at TA=25°C

Parameter	Symbol	Maximum size	Units
Power dissipation	PD	110	mW
Reverse Current	IF	30	mA
Peak Forward Current	IFP	100	mA
Reverse Voltage	VR	5	V
Operating Temperature		-40°C To +85°C	
Storage Temperature		-40°C To +85°C	

Pulse Width.  $\leq$  0.1msec : Duty Cycle  $\leq$  1/10

Typical light - electric curve:

Forward Current vs. Dominant wavelength

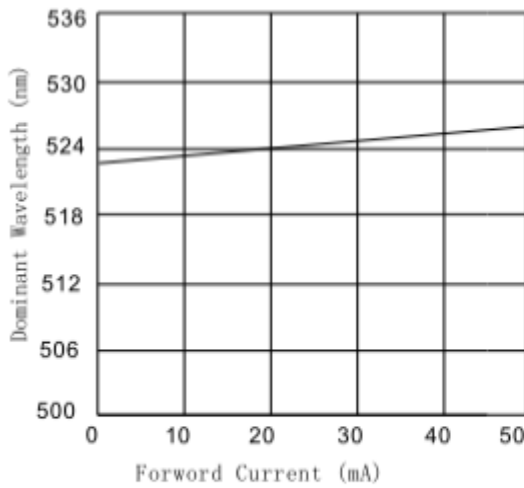

Relative Intensity vs. Ambient Temperature

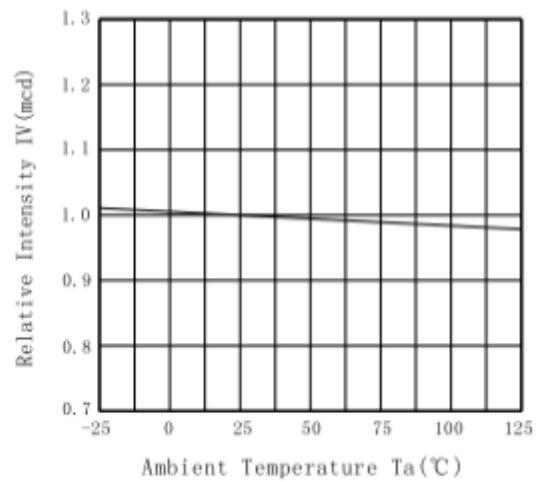

Forward Current vs. Forward Voltage

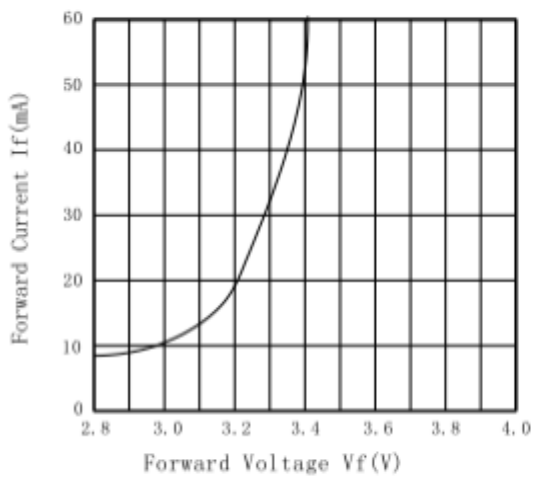

Forward Voltage vs. Ambient Temperature

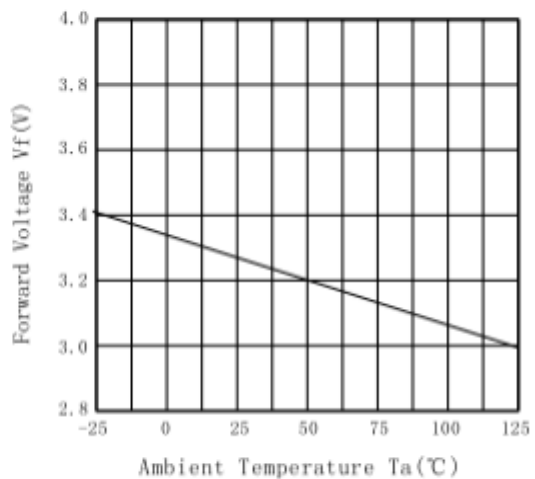

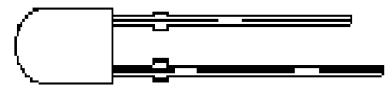
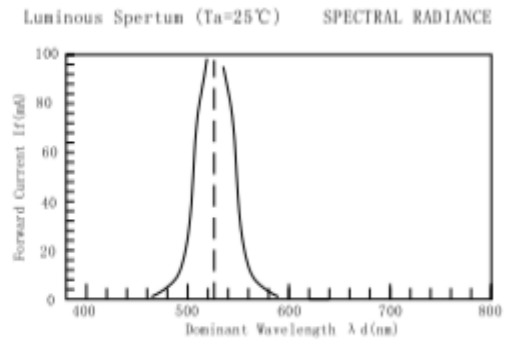
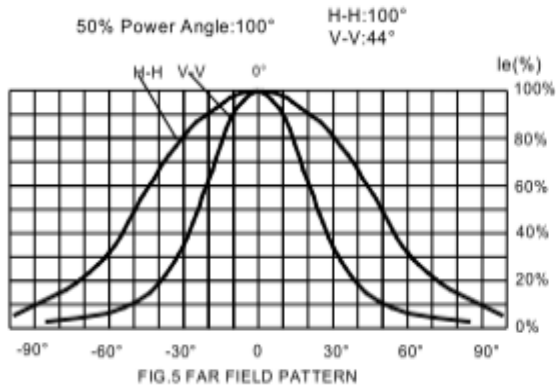

Drying agent

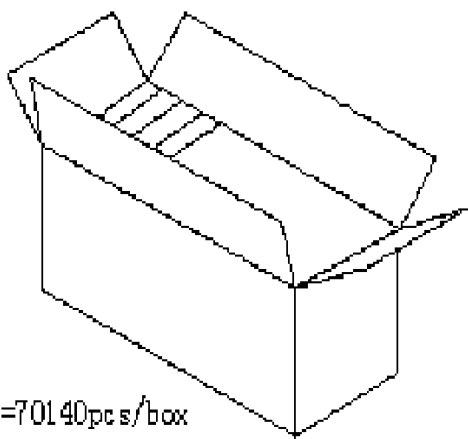
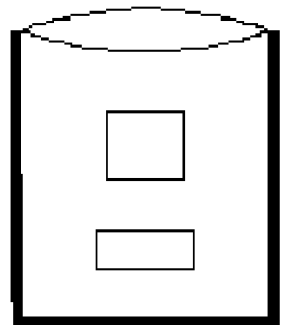

BOX(70包)  
70×1002pcs=70140pcs/box

Anti-static Aluminum Bag  
1002PCS/Bag