



www.snowdragonledhk.com

Good quality & Fast delivery

Snowdragon Industrial Co.,Ltd

DATA SHEET

MODEL No : **SDL518WCU-0-HD-A**

ENG. No: **09060907**

- 5mm Helmet
- Lens Color: Water Clear
- Emitting Color: White
- No Stopper
- Viewing Angle : 110°

Chip: InGaN

PREPARED BY	CHECKED BY	APPROVED BY
CUSTOMER APPROVED SIGNATURES		



Applications:

Dimension Drawing

Absolute Maximum Ratings at Ta = 25°C

Items	Symbol	Absolute maximum Rating	Unit
Items	I_F	25	mA
Forward Current	I_{FP}	100	mA
Peak Forward Current*	V_R	5	V
Reverse Voltage	P_D	100	mW
Power Dissipation	T_{opr}	-20 ~ +75	°C
Operation Temperature	T_{stg}	-30 ~ +80	°C
Storage Temperature	T_{sol}	Max.260°C for 3 sec Max. (3mm from the base of the epoxy bulb)	

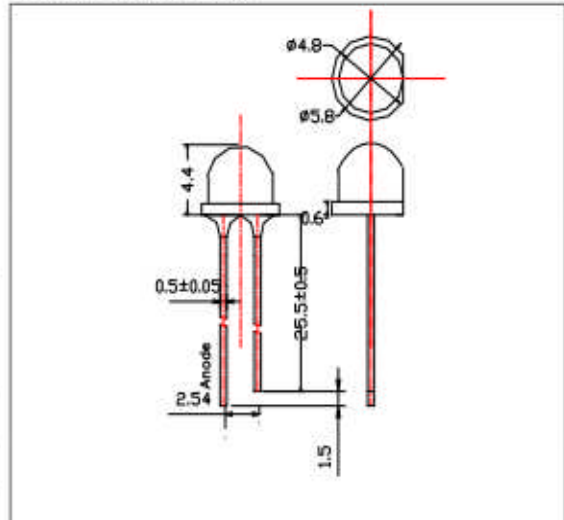

Notes:

- 1.All dimensions are in mm, Tolerance is ± 0.25 mm unless others noted
- 2.An epoxy meniscus may extend about 1.5mm
- 3.Burr around bottom of epoxy may be 0.5mm max.

*pulse width ≤ 0.1 msec duty $\leq 1/10$

Typical Electrical & Optical Characteristics (Ta = 25°C)

Items	Symbol	Condition	Min.	Typ.	Max.	Unit
Forward Voltage	V_F	$I_F = 20$ mA	2.8	3.2	3.6	V
Reverse Current	I_R	$V_R = 5$ V	---	---	10	μ A
Wavelength	CCT	$I_F = 20$ mA	---	7800	---	k
Luminous Intensity	I_V	$I_F = 20$ mA	--	3700	---	mcd
50% Power Angle	$2\theta_{1/2}$ H-H	$I_F = 20$ mA	---	110	---	deg
	$2\theta_{1/2}$ V-V	$I_F = 20$ mA	---	---	---	deg

Rank	Luminous Intensity(mcd)	Rank	Luminous Intensity(mcd)	Rank	Luminous Intensity(mcd)
/	/	/	/	/	/

Typical Optical-Electronic Characteristic Curves

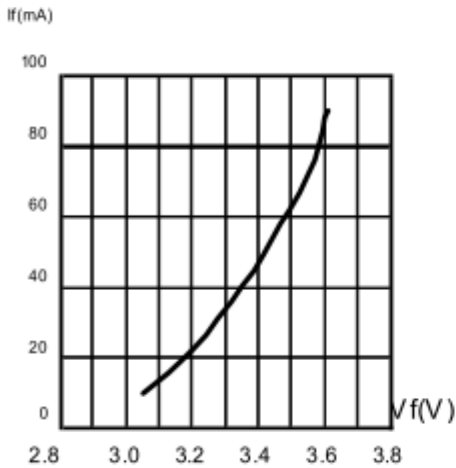

Fig.1 FORWARD CURRENT VS. FORWARD VOLTAGE.

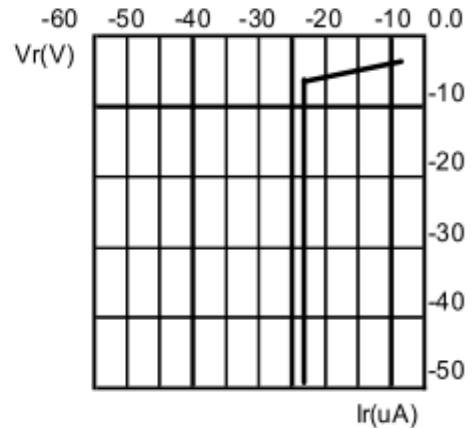

Fig.2 REVERSE CURRENT VS. REVERSE VOLTAGE.

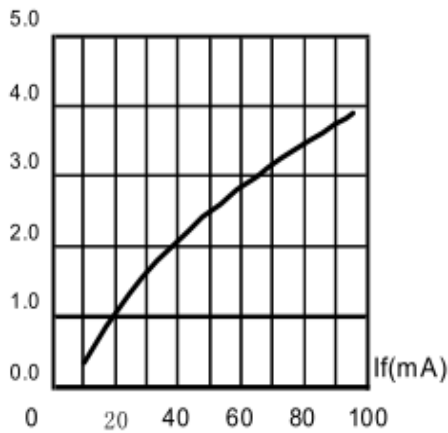

Fig.3 RELATIVE LUMINOUS INTENSITY VS. FORWARD CURRENT.

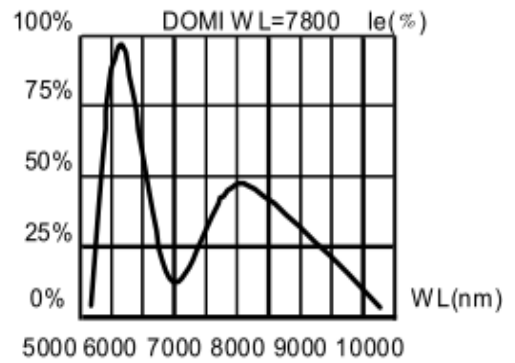
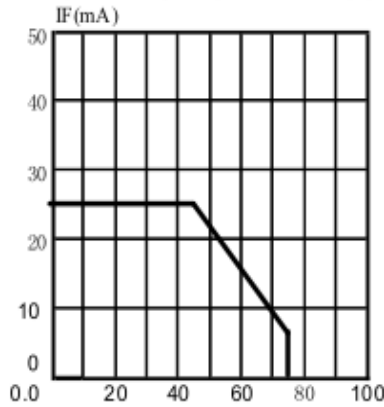

Fig.4 RELATIVE LUMINOUS INTENSITY



CURRENT VS AMBIENT TEMPERATURE(Tjmax=105)

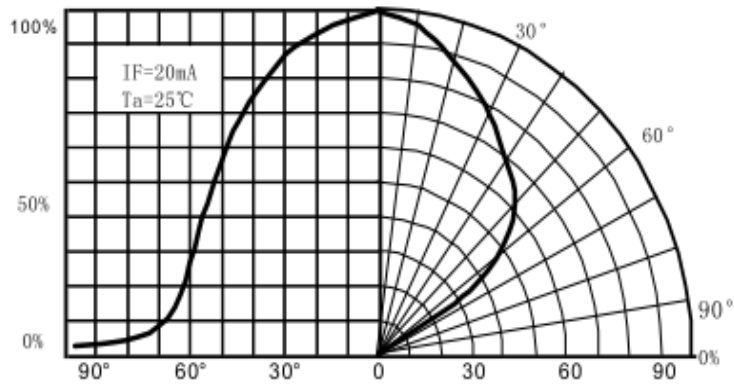

Fig.6 FAR FIELD PATTERN

LED Lamp Reliability test standard

Type	Test Item	REF. Standard	Test conditions		Note	Number of Damaged
			Binary / Trinary Chip	Quaternary Chip		
Environments Sequence	Temperature Cycle	JIS C7021 (1977)A4	-20°C~25°C~80°C~25°C 30min,5min,30min,5min	-40°C~25°C~100°C~25°C 30min,5min,30min,5min	100 cycles	0/100
	Thermal shock	MIL-STD-202G	-20°C~80°C 30min, 30min	-40°C~100°C 30min, 30min	100 cycles	0/100
	High Temperature Storage(*)	JIS C7021 (1977)B10	Ta=80°C	Ta=100°C	1000Hrs	0/100
	Low Temperature Storage	JIS C7021 (1977)B12	Ta=-30°C	Ta=-40°C	1000Hrs	0/100
Operation Sequence	Life test	JIS C7035 (1985)	Ta=25°C If=25mA	Ta=25°C If=25mA	1000Hrs	0/100
	High humidity Heat life test	-----	60°C RH=90% If=20mA	60°C RH=90% If=20mA	500Hrs	0/100
	Low temperature Life test	-----	Ta=-20°C If=20mA	Ta=-30°C If=20mA	1000Hrs	0/100
Destructive Sequence	Resistance to solderingHeat	JIS C7021 (1977)A11	Tsol=260±5°C ,10sec. (3mm from the base of the epoxy bulb)		1 time	0/20
	Solder ability	JIS C7021 (1977)A2	Tsol=235±5°C ,5sec. (using flux)		1 time (over95%)	0/20
	Lead Pull/Bend Test	JIS C7021 (1977)A11	Load 2.5N(0.25kgf) 0°C~90°C~0°C;Bend 3times		3 time	0/10
ESD Test	ESD TEST	AEC (Q101002)	Human body model 1000v		-----	0/10

Failure Criteria

Item	Symbol	Test Condition	Criteria for Judgment	
			min	Max
Forward Voltage	VF	IF = 20 mA	-----	Initial Data x 1.1
Reverse Current	IR	VR = 5 V	-----	100 A
Luminous Flux/Intensity	/IV	IF = 20 mA	Initial Data x 0.7 (Total degradation) Initial Data x 0.5 (Single lamp degradation)	