



[www.snowdragonledhk.com](http://www.snowdragonledhk.com)

Good quality & Fast delivery

## Snowdragon Industrial Co.,Ltd

### DATA SHEET

**MODEL N.O.: SDP5GX-O-D**

**ENG. N.O.: 12050402**

**Description:**

- **Shape: 5mm Stawhat LED**
- **Emitting Color: Puregreen**
- **Lens Color : Water Clear**
- **Viewing Angle: 100°**
- **DiceMaterial: InGaN**

PREPARED BY	CHECKED BY	APPROVED BY
CUSTOMER APPROVED SIGNATURES		



Technology support or Order ,pls email us :[powerledmanufacturer@gmail.com](mailto:powerledmanufacturer@gmail.com)



[www.snowdragonledhk.com](http://www.snowdragonledhk.com)

Good quality & Fast delivery



### Applications :

- Advertising board
- Decoration Lighting
- Indicator light



### Dimension Drawing :

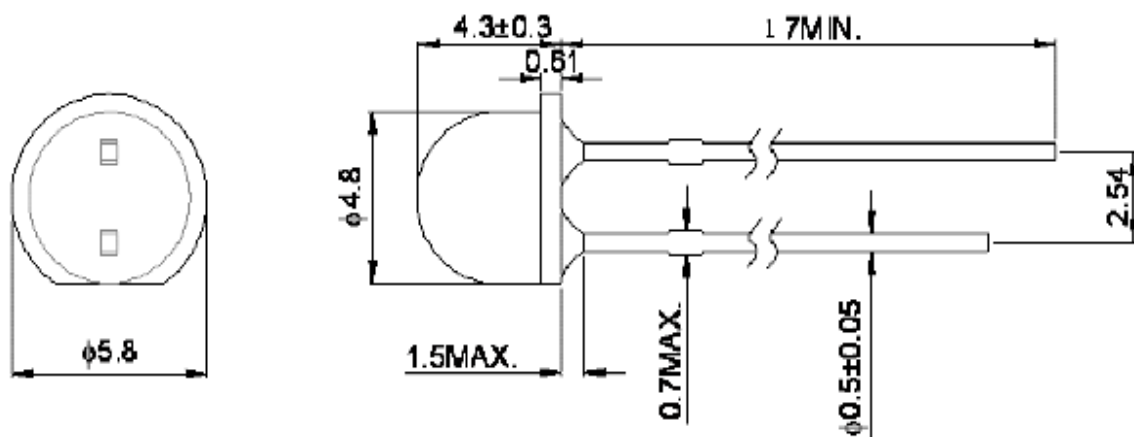

### Notes:

1. All dimensions are in mm, Tolerance is  $\pm 0.25$  mm unless others noted
2. An epoxy meniscus may extend about 1.5 mm
3. Burr around bottom of epoxy may be 0.5 mm max.

Technology support or Order ,pls email us :[powerledmanufacturer@gmail.com](mailto:powerledmanufacturer@gmail.com)



**Absolute Maximum Ratings (Ta = 25°C)**

Items	Symbol	Absolute maximum Rating	Unit
Forward Current	I <sub>F</sub>	30	mA
Peak Forward Current*	I <sub>FP</sub>	100	mA
Reverse Voltage	V <sub>R</sub>	5	V
Power Dissipation	P <sub>D</sub>	110	mW
Operation Temperature	T <sub>opr</sub>	-40 ~ +85	°C
Storage Temperature	T <sub>stg</sub>	-30 ~ +85	°C
Lead Soldering Temperature	T <sub>sol</sub>	Max.260°C for 3 sec Max. (3mm from the base of the epoxy bulb)	

\*pulse width <=0.1msec duty <=1/10

**Typical Electrical ( Ta = 25°C)**

Items	Symbol	Condition	Min.	Typ.	Max.	Unit
Forward Voltage	V <sub>F</sub>	I <sub>F</sub> = 20mA	---	3.1	---	V
Reverse Current	I <sub>R</sub>	V <sub>R</sub> = 5V	---	---	10	μA
Wavelength	λ <sub>D</sub>	I <sub>F</sub> = 20mA	523	---	526	nm
Luminous Intensity	I <sub>V</sub>	I <sub>F</sub> = 20mA	2000	---	3000	mcd
50% Power Angle	2θ <sub>1/2</sub> H-H	I <sub>F</sub> = 20mA	---	145	---	deg
	2θ <sub>1/2</sub> V-V	I <sub>F</sub> = 20mA	---	---	---	deg

**Important Notes :**

- 1) All ranks will be included per delivery, rank ratio will be determined by Snowdragon.
- 2) Tolerance of measurement of luminous intensity is ±15%.
- 3) Tolerance of measurement of dominant wavelength is ±1nm.
- 4) Tolerance of measurement of Vf is ±0.05 V.
- 5) Packaging methods are available for selection, please refer to PACKAGING STANDARD.
- 6) Please refer to LED LAMP RELIABILITY TEST STANDARD for reliability test conditions.



[www.snowdragonledhk.com](http://www.snowdragonledhk.com)

Good quality & Fast delivery

### Typical Optical-Electronic Characteristic Curves

Forward Current vs. Ambient Temperature

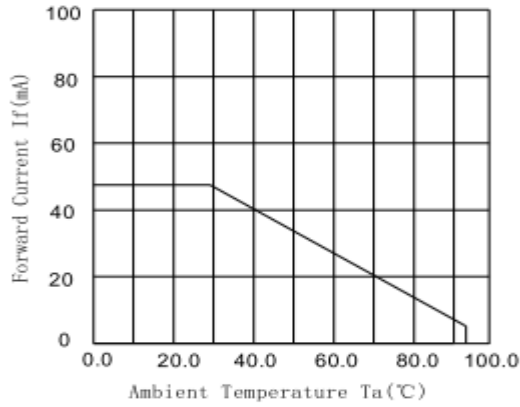

Relative Intensity vs. Ambient Temperature

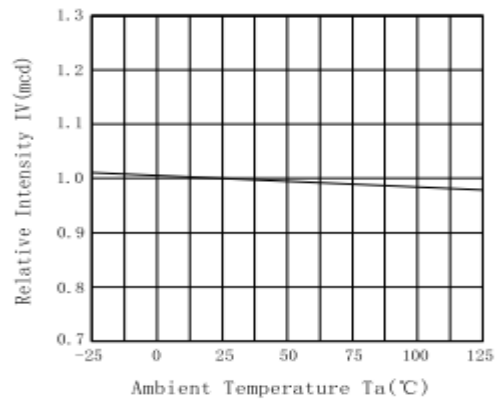

Forward Current vs. Forward Voltage

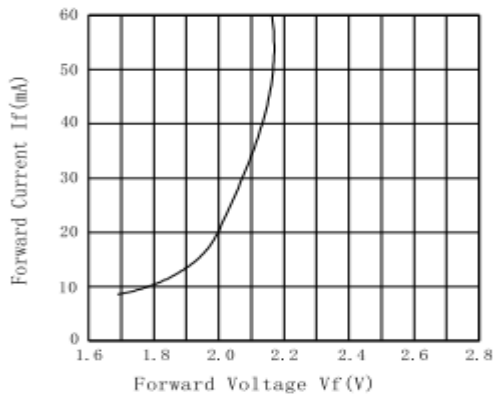

Forward Voltage vs. Ambient Temperature

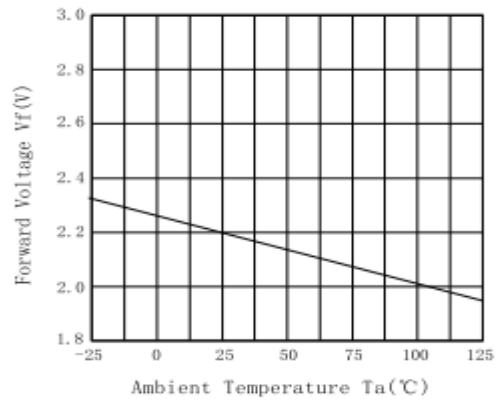

50% Power Angle: 145°

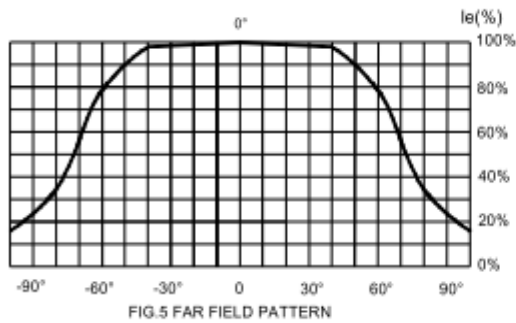

Luminous Spertun ( $T_a=25^\circ\text{C}$ ) SPECTRAL RADIANCE

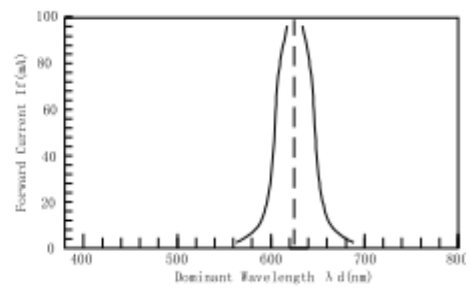

Technology support or Order ,pls email us :[powerledmanufacturer@gmail.com](mailto:powerledmanufacturer@gmail.com)



**Purpose:**

This document describes the main customers and users on how to better use our LED products  
Instructions for use:

In general, LED semiconductor with the same general usage. When using the LED product, please observe the following to use to protect the product.

1. cleaning methods:

Do not use an unknown chemical liquid cleaning products: an unknown chemical liquid may damage the product. When necessary, cleaning, wipe the product with alcohol, and natural drying for 15 minutes, then get started.

2. Anti-moisture packing method:

In order to avoid transportation and storage of products in the moisture, the product packaging is packed with moisture-proof aluminum bags, and bags which contains desiccant, desiccant bags packed the main play control of the humidity.

3. Storage:

A. stored in sealed bags conditions of temperature 10-30 °C, humidity 40-70% RH, please try to use within 3 months due to improper pin to prevent the oxidation of preservation.

B. exposure led to wear wrist strap is required to wear anti-static-static shoes or gloves, work surfaces should also grounded, promptly after the opening sealed bag sto prevent the pin oxidation.

4. Plug-in ESD protection, please note that:

A. indecent machine before production equipment grounding line is working.

B. inspectors static ring is normal, check whether the static ring close contact with human skin.

C. In the plug-in required operator is best to wear gloves or a good static static finger sets.

D, job requirements laid table static tape, adhesive tape between the ground should be connected to each other.

E, Kaifeng, please run out within 24 hours, or feet may cause oxidation of light rust.

5. welding line type led in four ways: manual welding, automatic welding, soldering tin stove, the peak soldering:

Manual Welding: General Electric ferrochromium temperature set at about 315 °C, welding time is not more than 5 seconds, the best in 3 seconds, no more than three times the number of welding. Electrical ferrochrome temperature selection components are generally based on tin wire may be, is not Unchanged.

Auto Spot: This solder generally based on conventional setting, soldering tin wire temperature component generally made by the setting, set the time for 3 seconds

Soldering tin stove: the general thrust of the review prior to use whether Yang furnace temperature set temperature not exceeding 235 °C ± 5 °C. Soldering time less than 5seconds.

Wave soldering: It is now more advanced welding, to selection of flux have different requirements, different types of flux, with different finish on the solder joint, preheat the length of time between the welding quality is also often point inspection tin surface Tin solution to regular replacement, the temperature to adjust the ingredients according to the tin, but the maximum should not exceed 260 °C ± 5 °C, the maximum time should not exceed 5 seconds. point inspection tin solution temperature, select the appropriate flux, should always clean the tin leaf Surface liquid.

Time units to be welded above the ground, machine-static should not exceed 30v, human body static electricity does not exceed 50v. Manual welding would be best to use chrome heated electric iron. in the cold and dry environment to minimize the workshop personnel move, to avoid static electricity.

Technology support or Order ,pls email us :[powerledmanufacturer@gmail.com](mailto:powerledmanufacturer@gmail.com)



increasing temperature the reverse leakage current, leakage current will be significantly increased, resulting in reduced life LED, please refer to our products The specification of the current - temperature corresponding to the curve.

7. the use of white light when particular attention to:

A. Different levels of white light can not mix, especially in areas of different color, or light color will appear uneven situation.

B. forward voltage is not the same level can not be strung together to use.

C. recommend the use of constant current drive LED, to ensure its service life.

8. LED in forming, bending light foot, light foot bent to the gel point at least 3mm from the bottom; not in the welding or soldering the bending light foot, the foot if you have to bend light, in the welding before.

9. Packaging

- 1) The box is not waterproof, and must make them away from water and moisture.
- 2) General anti-static bag or bags LED, the last use of cardboard boxes for packaging.
- 3) The use of cartons during transport to prevent collision damage due to external LED.
- 4) The amount of packaging bag of 1000 + 2 (spare) pcs.
- 5) 50pcs bags used for packaging into cartons.

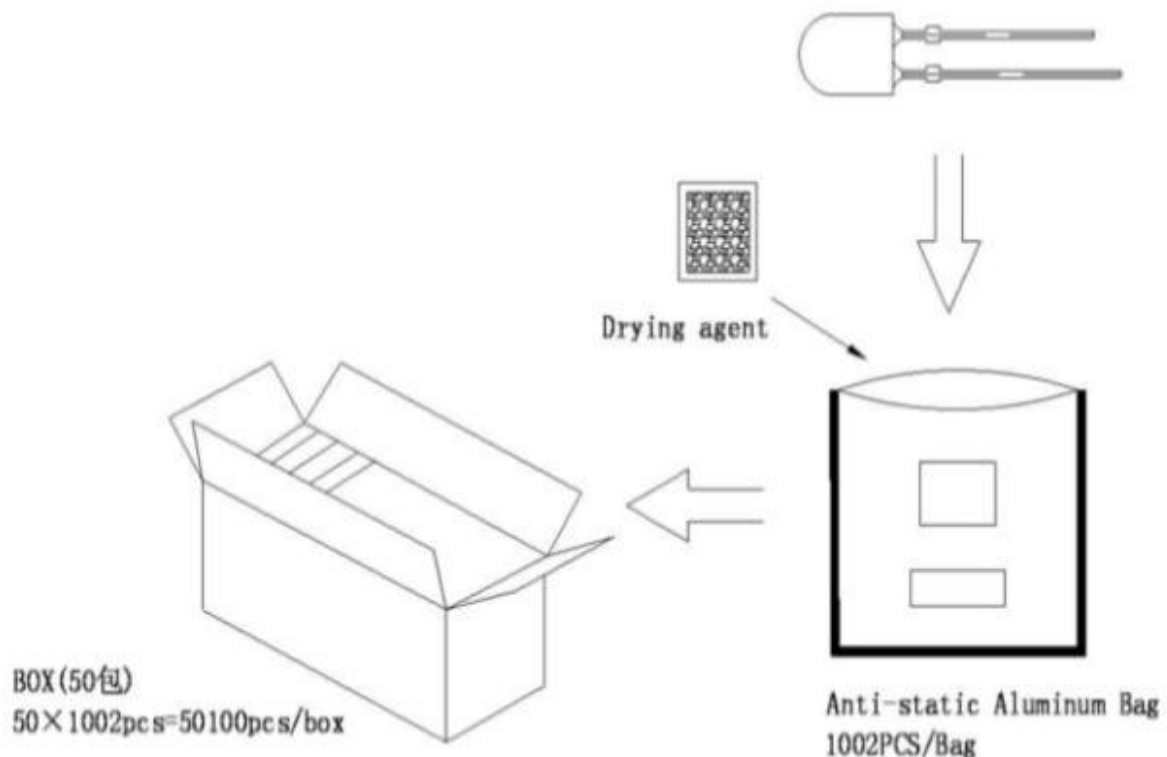







Technology support or Order ,pls email us :[powerledmanufacturer@163.com](mailto:powerledmanufacturer@163.com)











@gmail.com