



# Snowdragon Industrial Co.,Ltd

## DATA SHEET

**Model NO.:**SD-S5050TCU\_K1

**ENG. NO.:**2014022801

### Features:

- ※ **5.0\*5.0mm Chip SMD**
- ※ **Collid Color: Water Transparent**
- ※ **Emission Color: RGB**
- ※ **Viewing Angle: 120°**
- ※ **Cathode at the gap**

PREPARED BY	CHECKED BY	APPROVED BY
CUSTOMER APPROVED SIGNATURES		



Technology support & order , pls email : [powerledmanufacturer@gmail.com](mailto:powerledmanufacturer@gmail.com)

# 1. 外形尺寸 Dimensions

单位(Units):毫米(mm)

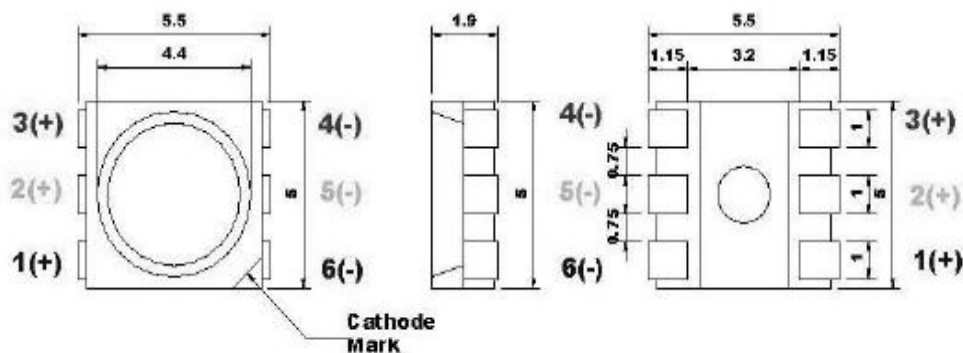

## Pin connection

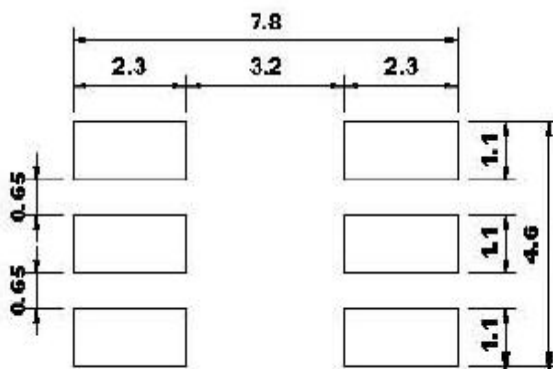

## 注意:

所有尺寸单位为 mm ， 如无特殊说明误差范围为±0.1mm

All dimensions area in mm tolerance is ±0.1mm unless otherwise noted.

## 2. 光电特性 Electrical / Optical characteristics

(1) 最大限度值 Absolute Maximum Ratings (TA=25±5°C)

项目Item	符号 Symbol	最大额定值 Absolute Maximum Rating	单位 Unit
正向电流Forward Current	IF	20	mA
正向峰值电流Pulse Forward Current	IFP	75	mA
反向电压Reverse Voltage	VR	15	V
功率消耗Power Dissipation	PD	80	mW
工作温度Operating Temperature	Topr	-40°C To +85°C	°C
贮藏温度Storage Temperature	Tstg	-40°C To +85°C	°C
焊接温度Soldering Temperature	Tsld	Reflow Soldering: 240°C Hand Soldering : 350°C	for 10sec. for 3sec.

1/10 周期, 0.1 msec 脉宽

IFP Conditions : 1/10 Duty Cycle, 0.1 msec Pulse Width.

(2) 样品光电参数 Initial Electrical/Optical Characteristics (TA=25±5°C)

符号 Symbol	项目 Item	单位 Units	最小值 Min.	规格值 Typ.	最大值 Max.	测试条件 Test Conditions	
VF	正向电压 Forward Voltage	V	R	1.9		2.1	IF=20mA
			G	3.0		3.4	IF=20mA
			B	3.0		3.4	IF=20mA
IR	反向电流 Reverse Current	uA			5	VR=5V	
2θ ½	发光角度 Viewing Angle	°		120°		IF=20mA	
øIV	发光强度 Luminous Intensity	Mcd	R	300		400	IF=20mA
			G	1000		1300	IF=20mA
			B	300		400	IF=20mA
λ D	主波长 Dominate Wavelength	Nm	R	620	625	630	IF=20mA
			G	519	520	527	IF=20mA
			B	466	470	475	IF=20mA

正向电压允许误差± 0.05V Tolerance of measurement of Vf is ±0.05 V.

亮度允许误差± 10% Luminous Intensity Measurement allowance is ± 10%.

### 3. 特性曲线 Characteristic curve

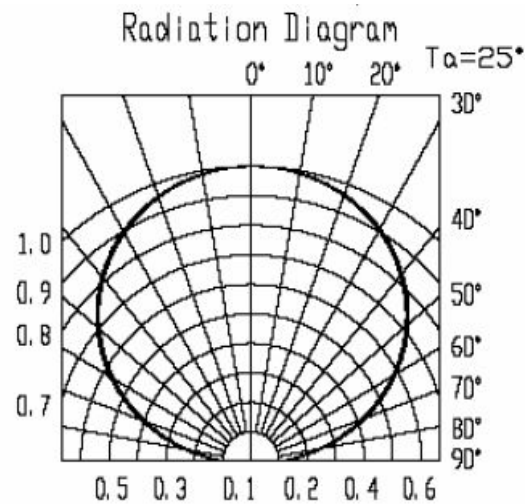
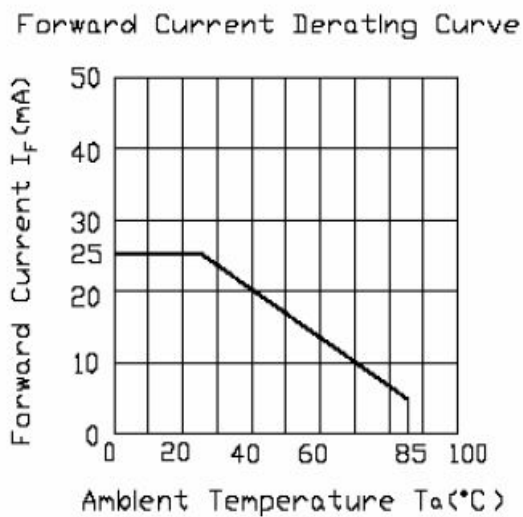
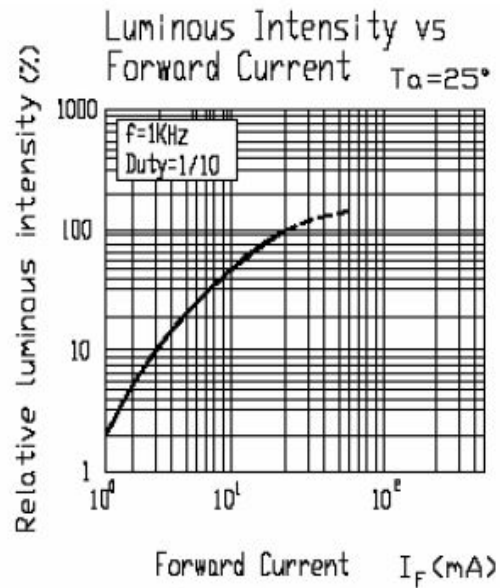
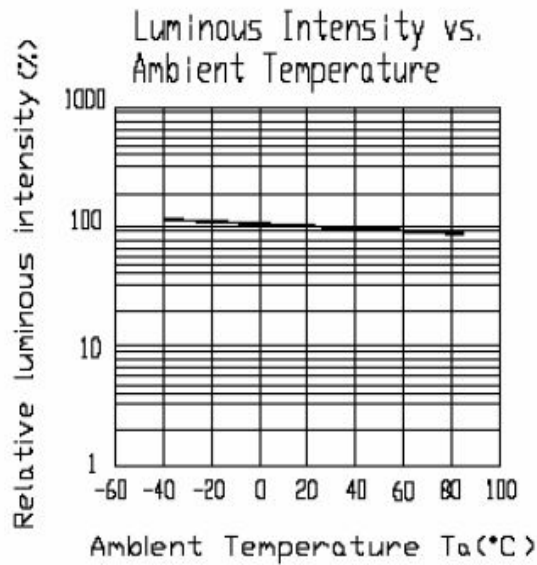
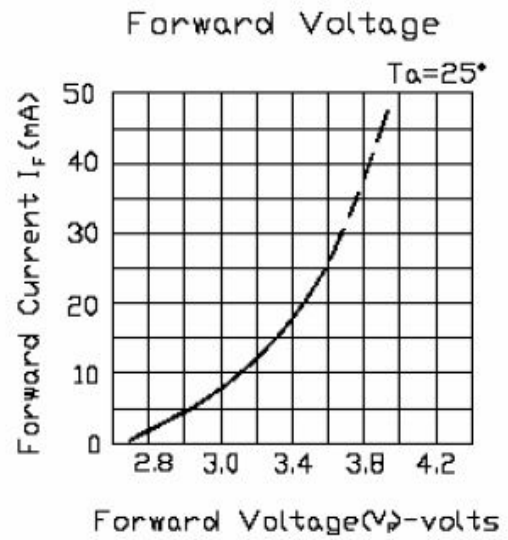
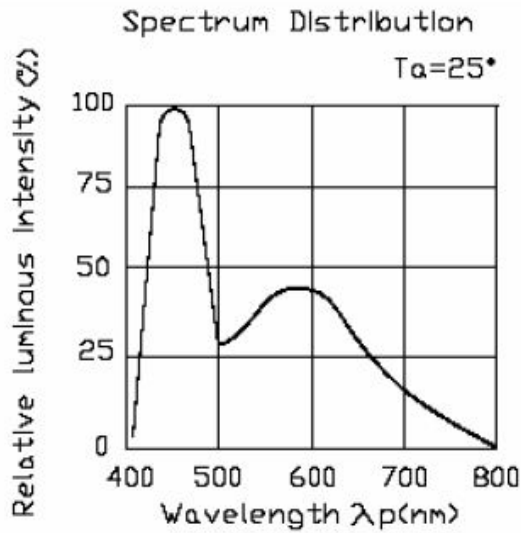



#### 4. 注意事项 Cautions

##### (1) 焊接条件 Soldering Conditions

本产品最多只可回焊两次,且在首次回焊后须冷却至室温之后方可进行第二次回焊.

Number of reflow process shall be less than 2 times and cooling process to normal temperature is required between first and Second soldering process.

推荐焊接条件(Recommended soldering conditions)

回流焊接 Reflow Soldering		手工焊接 Hand Soldering	
	有铅 Lead Solder	无铅 Lead-free Solder	温度 Temperature
预热温度 Pre-heat	140 ~ 160°C	180 ~ 200°C	350°C Max.
预热时间 Pre-heat time	120 sec. Max.	120 sec. Max.	焊接时间 Soldering time
峰值温度 Peak temperature	230°C Max.	260°C Max.	3 sec. Max. (one time only)
焊接时间 Soldering time	10 sec. Max.	10 sec. Max.	
条件 Condition	参考下图	参考下图	

有铅回焊 (Lead Solder)

无铅回焊 (Lead-Free Solder)

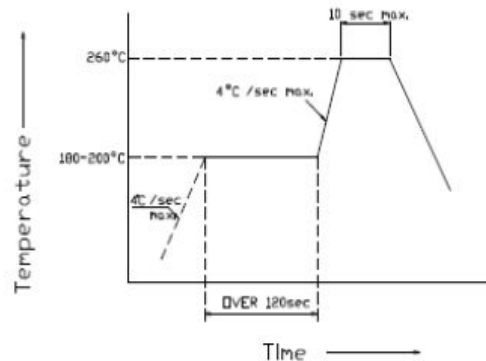
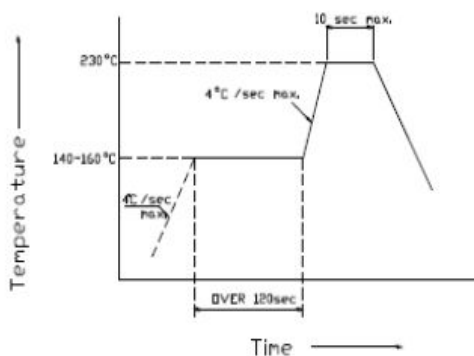

##### (2) 静电 Static Electricity

触摸 LED 时,推荐使用防静电手腕带或防静电手套.

It is recommended that a wrist band or an anti-electrostatic glove be used when handling the LEDs.

所有装置、设备、机器均应接地.

All devices, equipment and machinery must be properly grounded.

静电损坏的 LED 会显示出异常特征:正向电压变低或在低电流时死灯.标准:  $I_F=0.5\text{mA}$  时,  $V_F > 2.0\text{V}$

Damaged LEDs will show some unusual characteristics such as the forward voltage becomes lower, or the LEDs do not light at the low current. Criteria : ( $V_F > 2.0\text{V}$  at  $I_F=0.5\text{mA}$ )

##### (3) 防潮包装 Moisture Proof Package

使用防潮包装

It is recommended that moisture proof package be used

##### (4) 储藏 Storage

打开包装袋之前,LED 在温度为 30°C 或更低湿度 70%RH 以下,可保存一年.

Before opening the package, The LEDs should be kept at 30°C or less and 70%RH or less. The LEDs should be used within a year.

(5) 打开包装之后,应在 24hrs 内焊接完毕.

After opening the package, The LEDs should be soldered within 24 hours (1days) after opening the package.

(6) 抽真空包装的产品储存超过 1-3 个月, 重新使用时需烘烤 85°C/6H。

he product with vacuum packaging stored over 1-3 months, to be re-used baking 85 °C / 6H.

## 5. 包装 PACKAGING

(1) LEDS 在装带之后纸箱包装. The LEDs are packed in cardboard boxes after taping.

(2) 装带规格 Taping Specifications (单位:毫米 Units:mm)

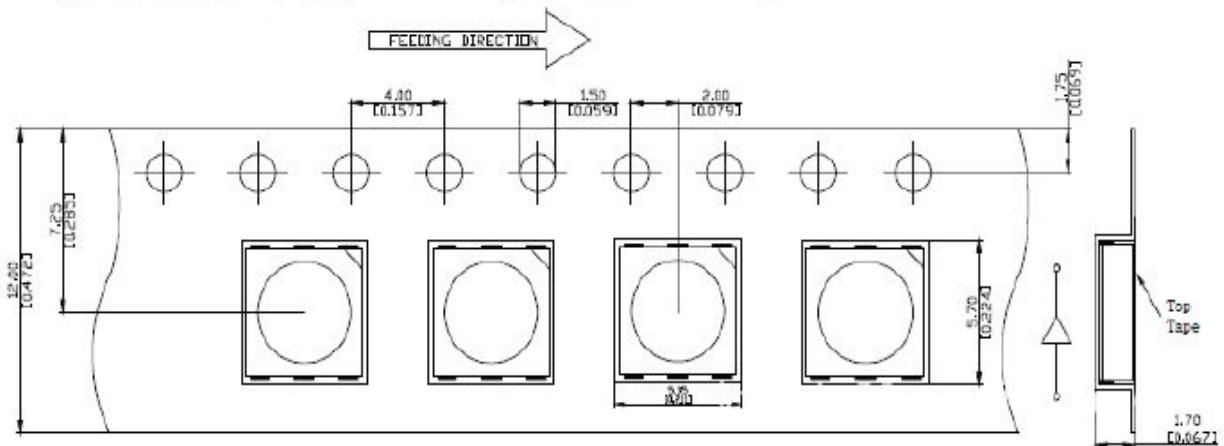

(3) 卷轴尺寸 Reel Dimension

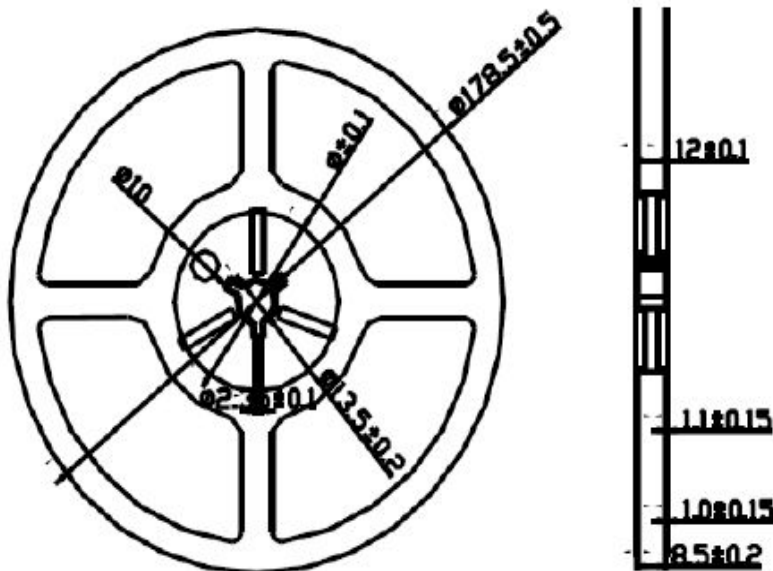

每卷数量 1000 个/卷 PACKAGE: 1000Pcs/Reel

(4) 最小包装标签注明以下:产品名称,批号,参数范围,数量.

The label on the minimum packing unit shows ; Part Number, Lot Number, Ranking, Quantity.

(5) 请注意防水防潮

Keep away from water, moisture in order to protect the LEDs.

(6) 须采取适当防护措施,以防包装箱跌落或受到强力撞击造成对产品的损伤.

The LEDS may be damaged if the boxes are dropped or receive a strong impact against them. so precautions must be taken to prevent any damage.